

The information disclosed herein was originated by and is the property of MAZeT. MAZeT reserves all patent, proprietary, design, use, sales, manufacturing and reproduction rights thereto. Product names used in this publication are for identification purposes only and may be trademark of their respective companies.	REVISIONS		
	REV.	DESCRIPTION	APPROVED
	1	V 1.1	2004-10-13

Preliminary Data Sheet

MTCSiCT

Integral True Colour Sensor – T05

Table of contents

1 FUNCTION2

2 APPLICATION2

3 FEATURES2

4 CONSTRUCTION3

5 ELECTRICAL CONNECTIONS3

6 MAXIMUM RATINGS / CHARACTERISTICS3

7 CHARACTERISTIC CURVE.....4

8 PACKAGE OVERVIEW5

9 PIN-CONFIGURATION.....6

10 APPLICATION CIRCUIT6

12 ORDERING INFORMATION.....7

MAZeT GmbH Sales Göschwitzer Straße 32 07745 JENA / GERMANY Phone: +49 3641 2809-0 Fax: +49 3641 2809-12 E-Mail: sales@MAZeT.de Url: http://www.MAZeT.de	Approvals	Date	MAZeT GmbH	
	Compiled:	2004-01-15	Status: preliminary	
	Checked:	2004-10-13		
	Released:	2004-10-13	DOC. NO: DB-04-138e	Page 1 of 7

REV.	DESCRIPTION	APPROVED
1	V 1.1	2004-10-13

1 FUNCTION

The colour sensors are made of 19 x 3 Si-PIN photo diodes integrated on chip. They are carried out as segments of a ring with the diameter of 2,0 mm. The design as Si-PIN photo diodes allows signal frequencies up to MHz-range. In order to achieve a small cross talk between the photodiodes the individual sectors were separated from each other by additional structures. Each of these photodiodes is sensitised with new dielectric spectral filter (named True Colour Filter¹) for its colour range, preferably for the primary colours red, green and blue.

2 APPLICATION

- Quality control
- Monitoring the production
- Control of manufacturing
- Detection of colour marks
- Colour measurement

3 FEATURES

Dielectric filters guaranties the good optical properties of the colour sensors, such as:

- high transmission
- slight ageing of the filter
- high temperature stability
- high signal frequency
- reduced cross talk
- small size (diameter of the optical sensitive surface ca. 2 mm)
- like tri-stimulus interference filter for colour measurement to DIN 5033 (&CIE LAB)

¹ The new generation of JENCOLOUR sensors is committed to implementing (see relative sensitivity) the standard distribution functions as defined under DIN 5033 Part 2 – Color Measurement; CIE 1931 Standard Colorimetric Systems. This implementation method allows colors to be determined according to the three-range procedure that is defined in part 6 of DIN 5033.

REV.	DESCRIPTION	APPROVED
1	V 1.1	2004-10-13

4 CONSTRUCTION

- 19 x 3 on chip integrated PIN photo diodes
- dielectric True Colour filters allow Colour Measurement to DIN 5033

5 ELECTRICAL CONNECTIONS

- three anodes
- one common cathode

6 MAXIMUM RATINGS / CHARACTERISTICS

($T_A = 25^\circ\text{C}$; per single diode)

Description	Symbol	Condition	typ. Value	Unit
Diameter of the light sensitivity area	D		2,0	mm
Light sensitivity area per element	A		0,85	mm ²
Photo sensitivity of colour ranges	S_{\max}	$\lambda_z = 445 \text{ nm}$ $\lambda_y = 555 \text{ nm}$ $\lambda_{xk} = 445 \text{ nm}$ $\lambda_{xl} = 600 \text{ nm}$	0,28 0,37 0,12 0,43	A/W
Spectral tolerance of filter curve	$\Delta\lambda(\lambda)$		<2%* λ	nm
Reverse Voltage	V_R	0...5V	2,5	V
Dark current	I_R	$V_R = 5V$	<200	pA
Terminal Capacitance	C	$V_R = 5V$	<100	pF
Rise and fall time of the photo-current	t_r, t_f		<2	μs
Noise equivalent power	NEP	$f_R = 100 \text{ Hz}$	<10 ⁻¹³	W/ $\sqrt{\text{Hz}}$
Cross-talk			<1	%
Angle of incidence	φ	$\Delta\lambda_{(\text{Filter})} < 1\%*\lambda$	8	Grad
Operating temperature range	T_{op}		0 ... +70	°C
Storage temperature range	T_{st}		-20 ... +80	°C

REVISIONS		
REV.	DESCRIPTION	APPROVED
1	V 1.1	2004-10-13

7 CHARACTERISTIC CURVE

Typical (relative) sensitivity (XYZ) of the colour sensor (MTCSiCT)

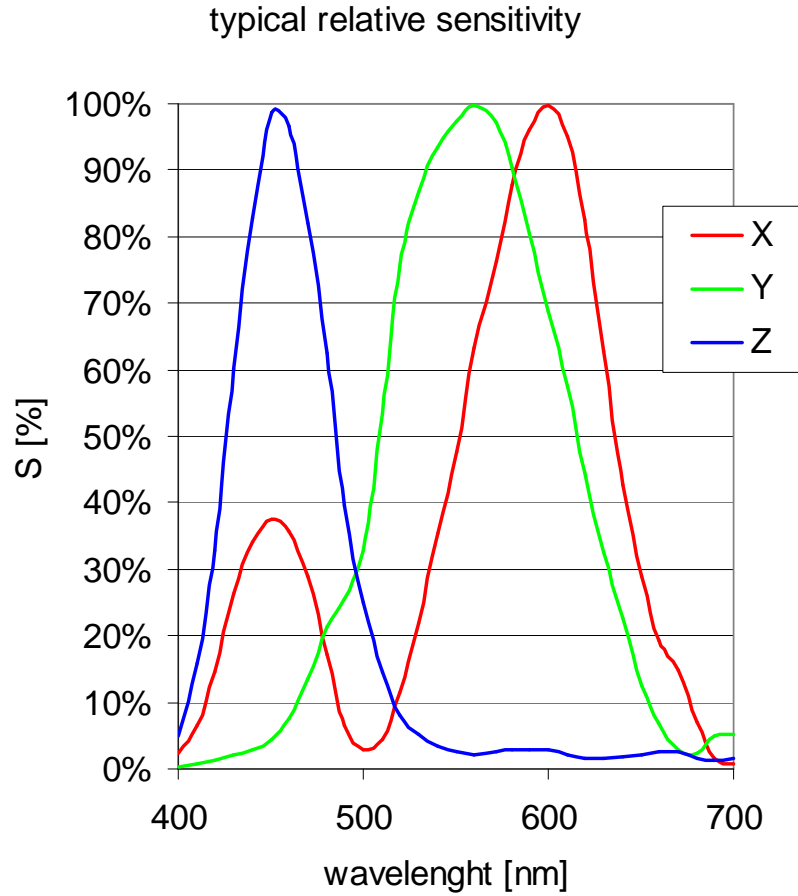

REV.	DESCRIPTION	APPROVED
1	V 1.1	2004-10-13

8 PACKAGE OVERVIEW

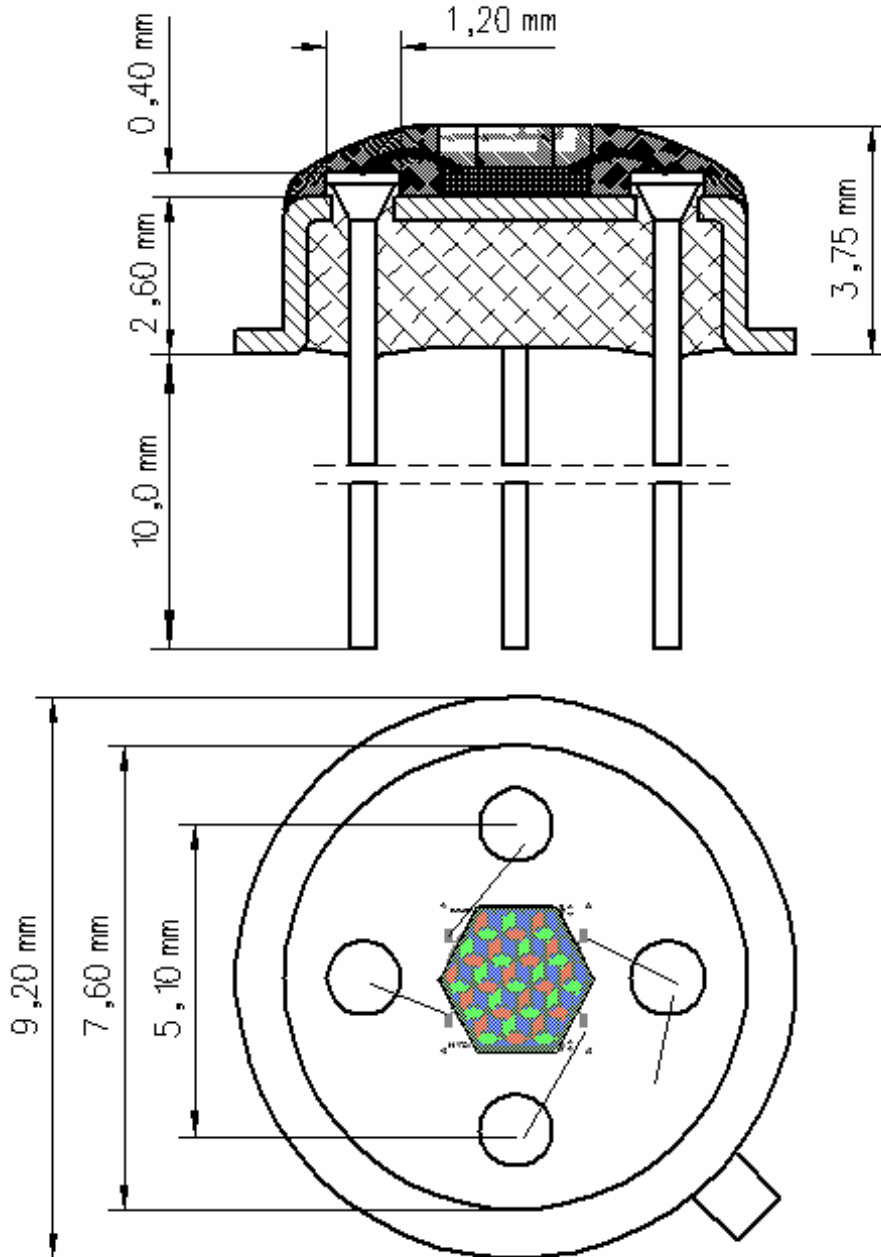

MTCSiCT in TO5 package
with additional IR blocking

REVISIONS		
REV.	DESCRIPTION	APPROVED
1	V 1.1	2004-10-13

9 PIN-CONFIGURATION

(Top view)

PIN	description
1	A1 X
2	A2 Y
3	A3 Z
K	common cathode

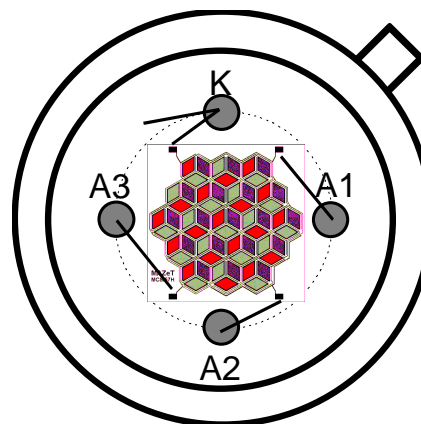

TO5-package

10 APPLICATION CIRCUIT

Opposite figure shows a circuit for the conversion of photo current to an equivalent voltage. These voltage can be processed e.g. with an ADC. By the selection of suitable resistors the output voltage range can be adjusted to the photo current value.

(for example the pin-programmable transimpedance amplifier MT104 with the resistors 25kΩ, 500kΩ and 5MΩ)

$$R_x \approx \frac{V_{Out}}{I_{Photo}}$$

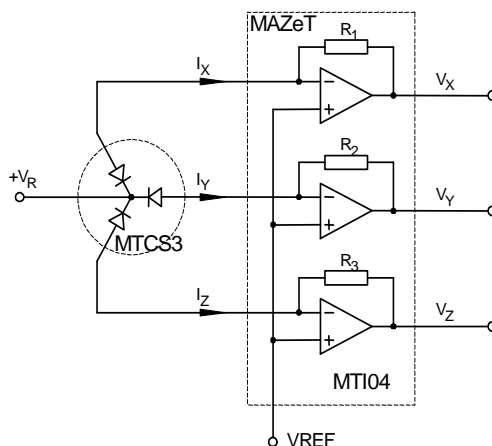

REV.	DESCRIPTION	APPROVED
1	V 1.1	2004-10-13

12 ORDERING INFORMATION

True Colour sensor with TO5-package, IR-blocking
Evaluation board for JENCOLOUR sensors

MTCSiCT
MCS-EB1

For more detailed information please contact:

MAZeT GmbH
Sales office:
Frank Krumbein
Göschwitzer Straße 32
07745 JENA
GERMANY
Phone: +49 3641 2809-17
Fax: +49 3641 2809-12
E-Mail: krumbein@MAZeT.de
Url: <http://www.MAZeT.de>