

The information disclosed herein was originated by and is the property of MAZeT. MAZeT reserves all patent, proprietary, design, use, sales, manufacturing and reproduction rights thereto. Product names used in this publication are for identification purposes only and may be trademark of their respective companies.	REVISIONS		
	REV.	DESCRIPTION	APPROVED
	1	V 1.3	2001-03-20

Data Sheet

MCS3AO

3-element colour sensor – TO5 with optics

Table of contents

1 FUNCTION	2
2 APPLICATION	2
3 FEATURES	2
4 CONSTRUCTION	2
5 MAXIMUM RATINGS / CHARACTERISTICS.....	3
6 CHARACTERISTIC CURVE.....	3
7 PACKAGE OVERVIEW	4
8 PIN-CONFIGURATION	4
9 APPLICATION CIRCUIT	5
10 APPLICATION NOTE	5
11 ORDERING INFORMATION.....	5

MAZeT GmbH Sales Göschwitzer Straße 32 07745 JENA / GERMANY Phone: +49 3641 2809-0 Fax: +49 3641 2809-12 E-Mail: sales@MAZeT.de Url: http://www.MAZeT.de	Approvals	Date	MAZeT GmbH	
	Compiled:	2001-02-21	Status: valid	
	Checked:	2001-03-20		
	Released:	2001-03-20	DOC. NO: DB-99-080e	Page 1 of 5

REV.	DESCRIPTION	APPROVED
1	V 1.3	2001-03-20

1 FUNCTION

The colour sensors are made of 3 Si-PIN photo diodes integrated on chip. They are carried out as segments of a ring with the diameter of 2,0 mm. The design as Si-PIN photo diodes allows signal frequencies up to MHz-range. In order to achieve a small cross talk between the photodiodes the individual sectors were separated from each other by additional structures. Each of these photodiodes is sensitised with dielectric spectral filter for its colour range, preferably for the primary colours red, green and blue.

2 APPLICATION

- Quality control
- Monitoring the production
- Control of manufacturing
- Detection of colour marks

3 FEATURES

Dielectric filters guaranties the good optical properties of the colour sensors, such as:

- high transmission
- slight aging of the filter
- high temperature stability
- high signal frequency
- reduced cross talk
- small size (diameter of the optical sensitive surface ca. 2 mm)

4 CONSTRUCTION

- 3 on chip integrated PIN photo diodes
- package version TO5, with optical lense
- dielectric filters for the three colour ranges: red, green and blue
- Electrical connections
 - three anodes
 - one common cathode

REVISIONS		
REV.	DESCRIPTION	APPROVED
1	V 1.3	2001-03-20

5 MAXIMUM RATINGS / CHARACTERISTICS

(T_A = 25°C; per single diode)

Description	Symbol	Condition	typ. Value	Unit
Diameter of the light sensitivity area	D		2,0	mm
Light sensitivity area per element	A		0,85	mm ²
Photo sensitivity of colour ranges	S _{max}	λ _B = 470 nm λ _G = 570 nm λ _R = 650 nm	0,26 0,33 0,41 (0,25)	A/W
Field of the spectral sensitivity ± 2%*λ	λ _B λ _G λ _R		400 - 510 490 - 610 590 - 750	nm
Reverse Voltage	V _R	0...5V	2,5	V
Dark current	I _R	V _R = 5V	<100	pA
Terminal Capacitance	C	V _R = 5V	50	pF
Rise and fall time of the photocurrent	t _r , t _f		<1	μs
Noise equivalent power	NEP	f _R = 100 Hz	<10 ⁻¹³	W/√Hz
Crosstalk			1	%
Angle of incidence	φ	Δλ _(Filter) < 1%*λ	8	Grad
Operating temperature range	T _{op}		0 ... +70	°C
Storage temperature range	T _{st}		-20 ... +80	°C

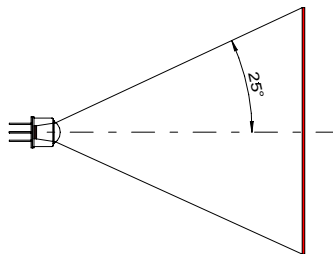

The optical lens allows the light collection at a acceptance angle width from 25°. In this case, the optimal work distance is 2 to 6 cm. The use of greater work distances is to be adapted by larger illumination intensity level.

6 CHARACTERISTIC CURVE

Typical spectral sensitivity of the 3-element colour sensor (MCS3)

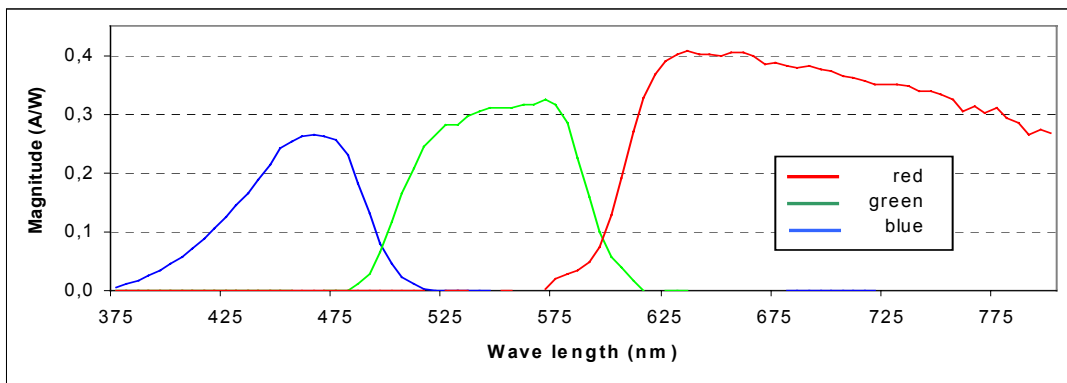

REVISIONS		
REV.	DESCRIPTION	APPROVED
1	V 1.3	2001-03-20

7 PACKAGE OVERVIEW

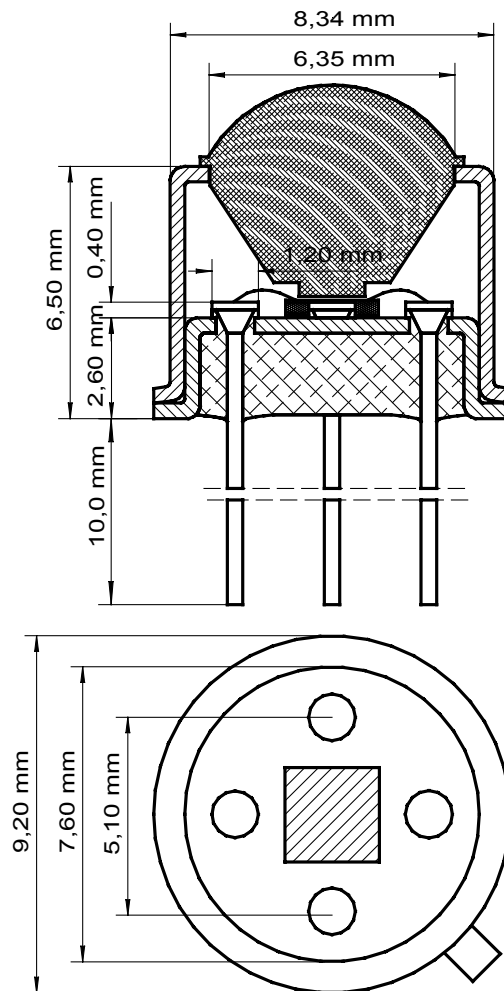

TO5 with optics (MCS3AO)

8 PIN-CONFIGURATION

(Top view)

PIN	description
1	A1 red
2	A2 blue
3	A3 green
K	common cathode

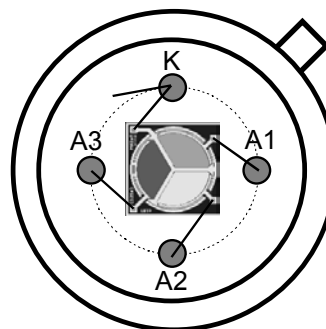

TO5-package

REV.	DESCRIPTION	APPROVED
1	V 1.3	2001-03-20

9 APPLICATION CIRCUIT

Opposite figure shows a circuit for the conversion of photo current to an equivalent voltage. These voltage can be processed e.g. with an ADC. By the selection of suitable resistors the output voltage range can be adjusted to the photo current value. (for example the pin-programmable transimpedance amplifier MTI04 with the

$$R_x \approx \frac{V_{Out}}{I_{Photo}} \quad \text{resistors } 25k\Omega, 500k\Omega \text{ and } 5M\Omega$$

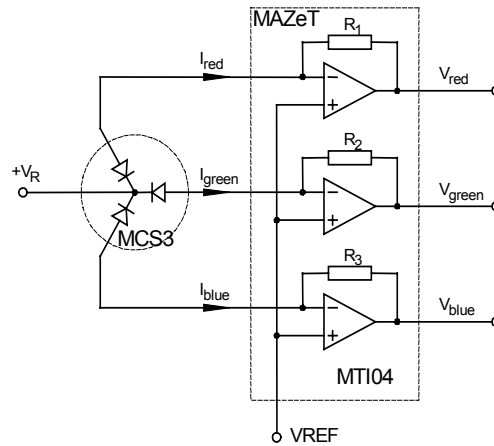

10 APPLICATION NOTE

It is recommended to use an IR-block filter > 720nm (MCS3BT) or a light source with low infrared radiation for optimal operations of the colour sensor.

11 ORDERING INFORMATION

Colour sensor with TO5-package with optical lense (plastic)
Evaluation board for JENCOLOUR sensors

MCS3AO
MCS-EB1

For more detailed information please contact:

MAZeT GmbH
Sales office:
Frank Krumbein
 Göschwitzer Straße 32
 07745 JENA
 GERMANY
 Phone: +49 3641 2809-0
 Fax: +49 3641 2809-12
 E-Mail: krumbein@MAZeT.de
 Url: <http://www.MAZeT.de>