

The information disclosed herein was originated by and is the property of MAZeT. MAZeT reserves all patent, proprietary, design, use, sales, manufacturing and reproduction rights thereto. Product names used in this publication are for identification purposes only and may be trademark of their respective companies.	REVISIONS		
	REV.	DESCRIPTION	APPROVED
	1	V1.11	2003-04-07

## Data Sheet

# MCS3AS

## 3-element colour sensor – SMD/SO8

### Table of contents

1 FUNCTION	2
2 APPLICATION	2
3 FEATURES	2
4 CONSTRUCTION	2
5 MAXIMUM RATINGS / CHARACTERISTICS	3
6 CHARACTERISTIC CURVES	3
6.1 Typical spectral sensitivity	3
6.2 Dark current	3
7 PACKAGE OVERVIEW	4
8 PIN-CONFIGURATION	5
9 APPLICATION CIRCUIT	5
10 APPLICATION NOTE	5
11 ORDERING INFORMATION	5

<b>MAZeT GmbH Sales</b> Göschwitzer Straße 32 07745 JENA / GERMANY Phone: +49 3641 2809-0 Fax: +49 3641 2809-12 E-Mail: sales@MAZeT.de Url: <a href="http://www.MAZeT.de">http://www.MAZeT.de</a>	<b>Approvals</b>	<b>Date</b>	<b>MAZeT GmbH</b>	
	Compiled:	2003-05-07	Status: valid	
	Checked:	2003-05-07		
	Released:	2003-05-07	DOC. NO: DB-99-073e	Page 1 of 5

REV.	DESCRIPTION	APPROVED
1	V1.11	2003-05-07

## 1 FUNCTION

The colour sensors are made of 3 Si-PIN photo diodes integrated on chip. They are carried out as segments of a ring with the diameter of 2,0 mm. The design as Si-PIN photo diodes allows signal frequencies up to MHz-range. In order to achieve a small cross talk between the photodiodes the individual sectors have been separated from each other by additional structures. Each of these photodiodes is sensitized with dielectric spectral filter for its colour range, preferably for the primary colours red, green and blue.



## 2 APPLICATION

- Quality control
- Monitoring the production
- Control of manufacturing
- Detection of colour marks

## 3 FEATURES

Dielectric filters guarantee the good optical properties of the colour sensors, such as:

- high transmission
- slight aging of the filter
- high temperature stability
- high signal frequency
- reduced cross talk
- small size (diameter of the optical sensitive surface ca. 2 mm)

## 4 CONSTRUCTION

- 3 on chip integrated PIN photo diodes
- dielectric filters for the three colour ranges: red, green and blue
- package design SOP8
- Electrical connections
  - three anodes
  - one separated diode for minimization of the cross-talk
  - one common cathode

REVISIONS		
REV.	DESCRIPTION	APPROVED
1	V1.11	2003-05-07

### 5 MAXIMUM RATINGS / CHARACTERISTICS

(TA = 25°C; per single diode)

Description	Symbol	Condition	typ. Value	Unit
Diameter of the light sensitivity area	D		2,0	mm
Light sensitivity area per element	A		0,85	mm <sup>2</sup>
Photo sensitivity of the colour ranges	S <sub>max</sub>	λ <sub>B</sub> = 470 nm λ <sub>G</sub> = 570 nm λ <sub>R</sub> = 650 nm	0,26 0,33 0,41	A/W
Field of the spectral sensitivity ± 2%*λ	λ <sub>B</sub> λ <sub>G</sub> λ <sub>R</sub>		400 - 510 490 - 610 590 - 750	nm
Reverse Voltage	V <sub>R</sub>	0...30 V	5	V
Dark current <small>** see 1.2 Typical characteristic</small>	I <sub>R</sub>	V <sub>R</sub> = 5V	<50	pA
Terminal Capacitance	C	V <sub>R</sub> = 5V	<50	pF
Rise and fall time of the photo-current	t <sub>r</sub> , t <sub>f</sub>		<1	μs
Noise equivalent power	NEP	f <sub>R</sub> = 100Hz	<10 <sup>-13</sup>	W/√Hz
Cross talk			1	%
Angle of incidence	φ	Δλ <sub>(Filter)</sub> < 1%*λ	8	Grad
Operating temperature range	T <sub>op</sub>		0 ... +70	°C
Storage temperature range	T <sub>st</sub>		-20 ... +80	°C
Soldering temperature		max. 3sec	max. +215	°C
MSL (Moisture Sensitivity Level)		-	1	-

### 6 CHARACTERISTIC CURVES

#### 6.1 Typical spectral sensitivity

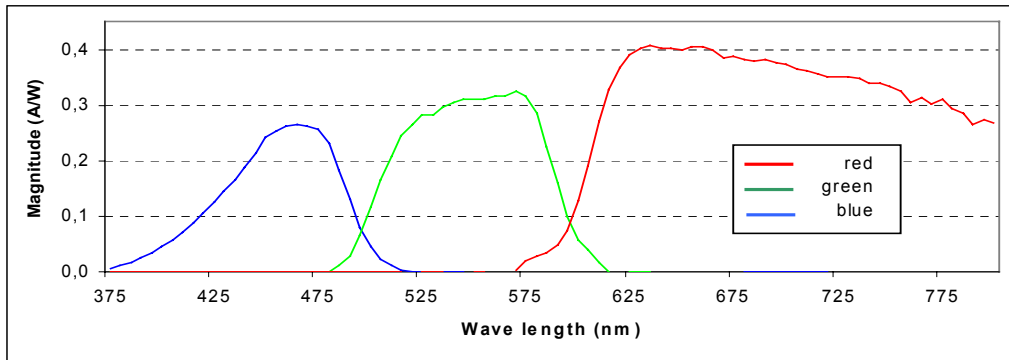

#### 6.2 Dark current

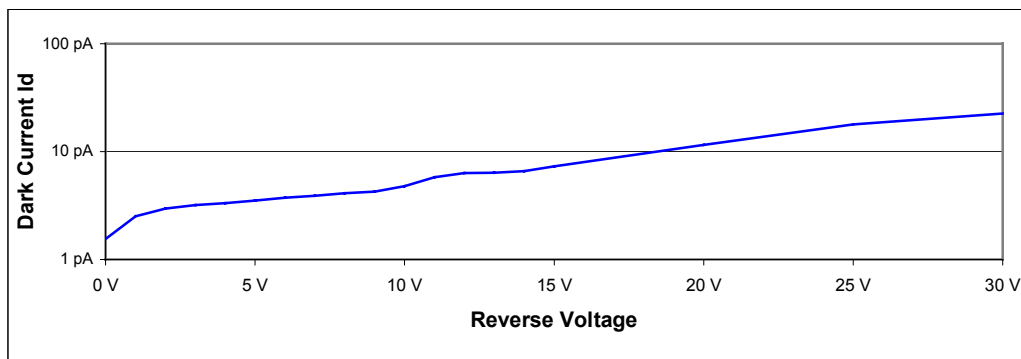

REVISIONS		
REV.	DESCRIPTION	APPROVED
1	V1.11	2003-05-07

**7 PACKAGE OVERVIEW**

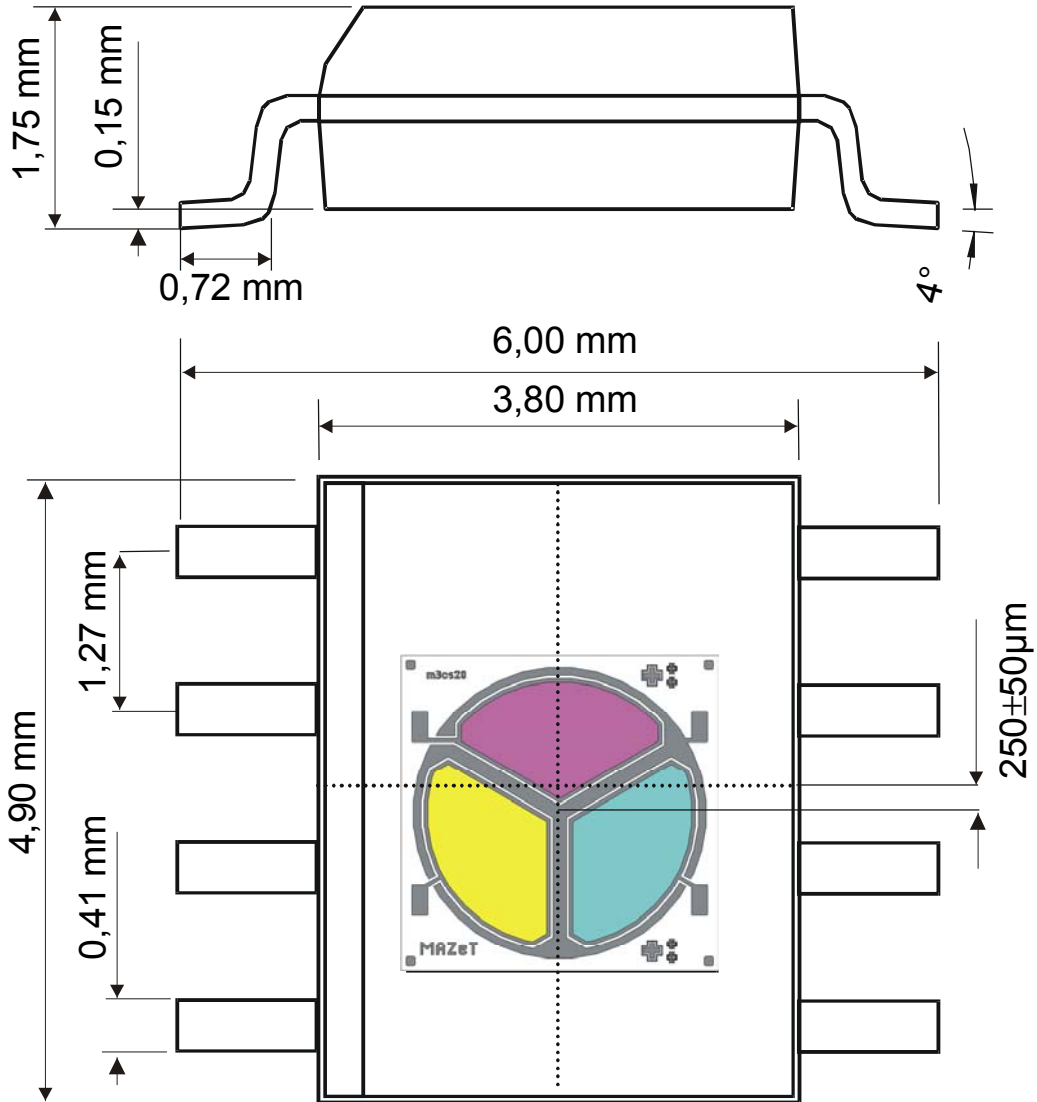

SOP8 Package (MCS3AS)

∅ diodes 2mm

REVISIONS		
REV.	DESCRIPTION	APPROVED
1	V1.11	2003-05-07

### 8 PIN-CONFIGURATION

(Top view)

PIN	description
1	A3 green
2	nc
3	nc
4	A2 blue
5	A1 red
6	nc
7	TrD
8	K common cathode

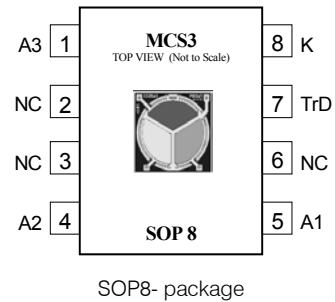

### 9 APPLICATIONCIRCUIT

Opposite figure shows a circuit for the conversion of photo current to an equivalent voltage. These voltage can be processed e.g. with an ADC. By the selection of suitable resistors the output voltage range can be adjusted to the photo current value.

$$R_x \approx \frac{\Delta V_{Out}}{\Delta I_{Photo}}$$

500kΩ and 5MΩ)

(for example the pin-programmable transimpedance amplifier MT104 with the resistors 25kΩ,

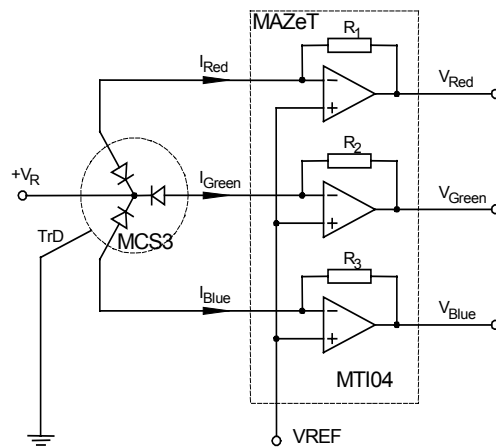

### 10 APPLICATION NOTE

It is recommended to use a light source with low infrared radiation for optimal operations of the colour sensor.

The separated diode can be connected with the cathode or connected to ground.

### 11 ORDERING INFORMATION

Colour sensor MCS3 with SOP8-package + transparent encapsulated (plastic) **MCS3AS**  
 Evaluation board for JENCOLOUR sensors **MCS-EB1**

For more detailed information please contact:

**MAZeT GmbH**  
**Sales office:**  
**Frank Krumbein**  
 Göschwitzer Straße 32  
 07745 JENA  
 GERMANY  
 Phone: +49 3641 2809-0  
 Fax: +49 3641 2809-12  
 E-Mail: krumbein@MAZeT.de  
 Url: <http://www.MAZeT.de>