

The information disclosed herein was originated by and is the property of MAZeT. MAZeT reserves all patent, proprietary, design, use, sales, manufacturing and reproduction rights thereto. Product names used in this publication are for identification purposes only and may be trademark of their respective companies.	REVISIONS		
	NO	VERSION	APPROVED
	1	V 1.3	2001-01-10

## DATA-SHEET

# MTI04Bx / MTI08Bx

## MULTI-CHANNEL PROGRAMMABLE GAIN TRANSIMPEDANCE AMPLIFIER

### Contents

<b>1. GENERAL DESCRIPTION</b>	<b>2</b>
<b>2. BLOCK DIAGRAM</b>	<b>2</b>
<b>3. INTERFACE DESCRIPTION</b>	<b>3</b>
3.1 Pinning	3
3.2 Adjustment of Transimpedance	3
<b>4. FUNCTION DESCRIPTION</b>	<b>3</b>
<b>5. ELECTRICAL CHARACTERISTICS</b>	<b>3</b>
5.1 Absolute Maximum Ratings	3
5.2 Operating Conditions	4
5.3 AC/DC-Characteristics	4
5.3.1 Offset Voltage At Input INX	5
5.3.2 Leakage Current At Input INX	6
5.3.3 DC-Transfer-Curves	7
<b>6. PACKAGES</b>	<b>8</b>
6.1 Shape and Dimensions	8
6.2 Pin-Configuration	8
<b>7. APPLICATIONS</b>	<b>9</b>
7.1 Example for Position Measurement	9
7.2 Connection of A Colour Sensor	9
<b>8. ORDERING INFORMATION</b>	<b>10</b>
<b>9. CONTACT</b>	<b>10</b>

<b>MAZeT GmbH</b> Sales office Göschwitzer Straße 32 D-07745 Jena / Germany Phone: +49/3641-2809-0 Fax: +49/3641-2809-12 Email: sales@MAZeT.de URL: http://www.MAZeT.de	<b>Approvals</b>	<b>Date</b>	<b>MAZeT GmbH</b>	
	Drawn:	2001-01-10	Status: DATA-SHEET	
	Checked:	2001-01-10		
	Released:	2001-01-10	DOC. NO: DB-99-072e	Sheet 1 OF 10

NO	VERSION	APPROVED
1	V 1.3	2001-01-10

## 1. GENERAL DESCRIPTION

The MTI-devices are a family of integrated circuits of **programmable gain transimpedance amplifiers** with **different numbers of channels** (4 or 8).

The MTI-devices are mainly used for **signal conditioning of sensors with current outputs**. Especially they are suitable for connection of photodiodes of **array and row sensors**.

The possibility to **adjust the transimpedance in 3 stages** is a special feature. The adjustment is made by programming of two pins and valid for all channels together.

The device packages are optimized for **COB-mounting**.

## 2. BLOCK DIAGRAM

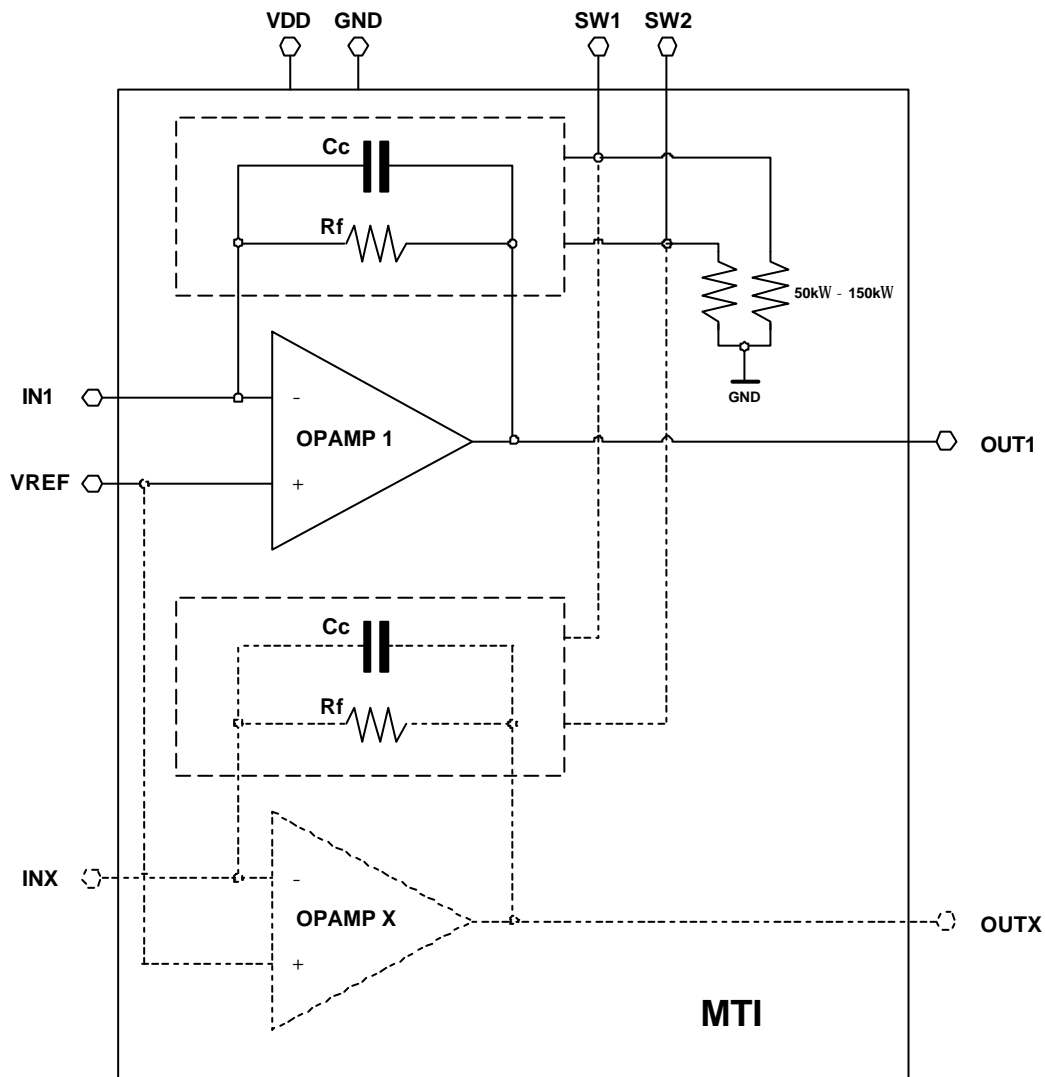

NO	VERSION	APPROVED
1	V 1.3	2001-01-10

### 3. INTERFACE DESCRIPTION

#### 3.1 Pinning

signal name	Typ.	a/d <sup>a</sup>	function
VDD	input	a/d	power supply (+)
GND	input	a/d	power supply (-)
SW1	input	d	input 1 for adjustment of transimpedance of MTI-amplifier (pull down)
SW2	input	d	input 2 for adjustment of transimpedance of MTI-amplifier (pull down)
INX	input	a	analog current input of amplifier X
OUTX	output	a	analog voltage output of amplifier X

a.) analog or digital

#### 3.2 Adjustment Of Transimpedance

settings of digital inputs		transimpedance R <sub>f</sub>
SW1	SW2	
VDD or GND	VDD	5M $\Omega$ – stage 1
VDD	GND	500k $\Omega$ – stage 2
GND	GND	25k $\Omega$ <sup>a</sup> – stage 3

a.) default by pull down

### 4. FUNCTION DESCRIPTION

The MTI-devices are programmable gain transimpedance amplifiers with different numbers of channels (MTI04 – 4 channels; MTI08 – 8 channels). Per channel there is one transimpedance amplifier between a current input INX and a voltage output OUTX. Its transimpedance is dialable in 3 stages. This adjustment can be effected by setting of digital inputs SW1 and SW2 and is valid for all channels simultaneously (headline 3.2). The inputs SW1 and SW2 are pulled down with a resistor for a default feedback resistor of 25k $\Omega$ .

The second input of all transimpedance amplifiers is used for a *common* supply by a reference voltage necessarily fed in through the pin VREF.

All channels are compensated for an external input capacitance of the photo-sensor of typical 20pF.

The power supply for the MTI-devices is typical 5V between VDD and GND.

### 5. ELECTRICAL CHARAKTERISTICS

#### 5.1 Absolute Maximum Ratings

Violations of absolute maximum ratings are not allowed under any circumstances. All voltages are referenced to VSS = 0V.

parameter	name	min.	max.	unit
power supply	VDD	-0,3	7,0	V
input and output voltages	⇒ IC-pinning	-0,3	VDD + 0,3	V
power dissipation	P <sub>OP</sub>		0,1	W
operating temperature	T <sub>OP</sub>	0	85	°C
storage temperature	T <sub>STG</sub>	-55	155	°C

NO	VERSION	APPROVED
1	V 1.3	2001-01-10

## 5.2 Operating Conditions

All voltages are referenced to VSS = 0V.

parameter	name	min.	typ.	max.	unit	condition
supply voltage	VDD	4,5	5	5,5	V	
Bias current MTI04	I(VDD)	3		4	mA	27°C
Bias current MTI08	I(VDD)	12		16	mA	27°C
operating temperature	T <sub>OP</sub>	0	27	85	°C	
input high level	V <sub>IH</sub>	2,0		VDD+0,3	V	
input low level	V <sub>IL</sub>	-0,3		0,8	V	
reference voltage	VREF	1	2,5	4	V	

## 5.3 AC/DC-Characteristics

Unless otherwise specified the data in this table is valid for T<sub>OP</sub> = 27°C and VDD = 5V.

parameter	name	min.	typ.	max.	unit	condition
input current	INX		0,1		μA	stage 1
			1		μA	stage 2
			20		μA	stage 3
feedback resistor	R <sub>f</sub>	4000	5000	6000	kΩ	stage 1
		400	500	600	kΩ	stage 2
		20	25	30	kΩ	stage 3
signal frequency at input	f <sub>3dB</sub>		25		kHz	stage 1
			70		kHz	stage 2
			500		kHz	stage 3
temperature coefficient of the feedback resistor	TC <sub>Rf</sub>		-3500		ppm/K	
input offset voltage	V <sub>OFF</sub>			8	mV	T <sub>OP</sub> = 85°C
input leakage current	I <sub>LEAK</sub>			500	pA	T <sub>OP</sub> = 85°C
capacitive load at OUTX	C <sub>LOAD</sub>			50	pF	I <sub>LOAD</sub> = 0,5mA
output voltage noise	V <sub>NOISE</sub>		tbd		nV/√Hz	f = 1kHz
equivalent input current noise	I <sub>NOISE</sub>		tbd		pA/√Hz	f = 1kHz
pull down resistor at SW1 and SW2	R <sub>PDSW</sub>	50			kΩ	
input capacitance of external connected photo-sensors	C <sub>DIODE</sub>		20		pF	per input

REVISIONS		
NO	VERSION	APPROVED
1	V 1.3	2001-01-10

5.3.1 Offset Voltage At Input INX

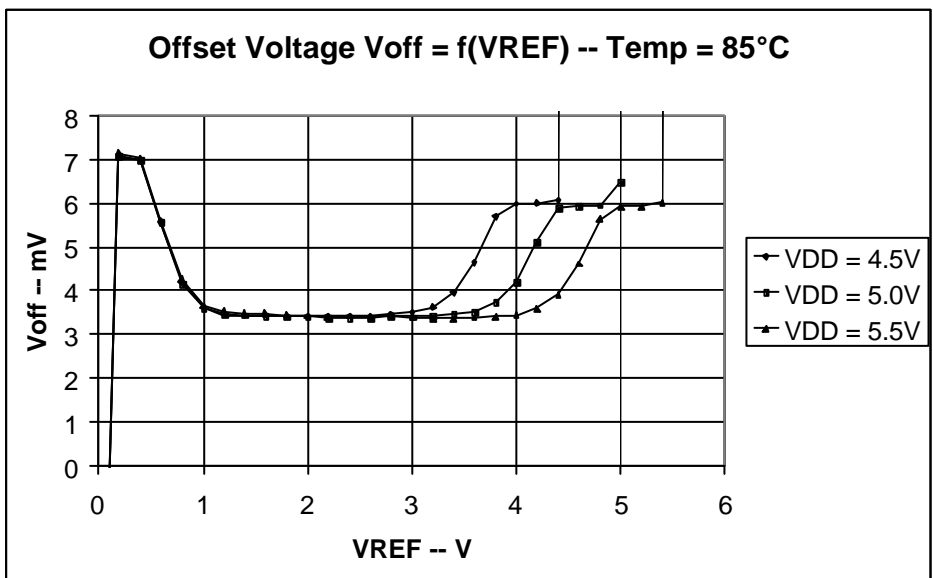
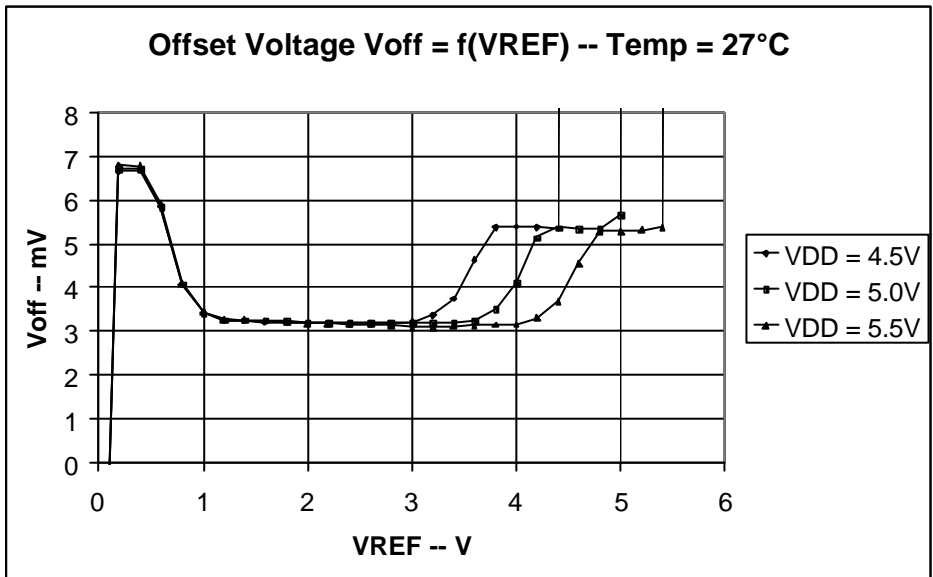
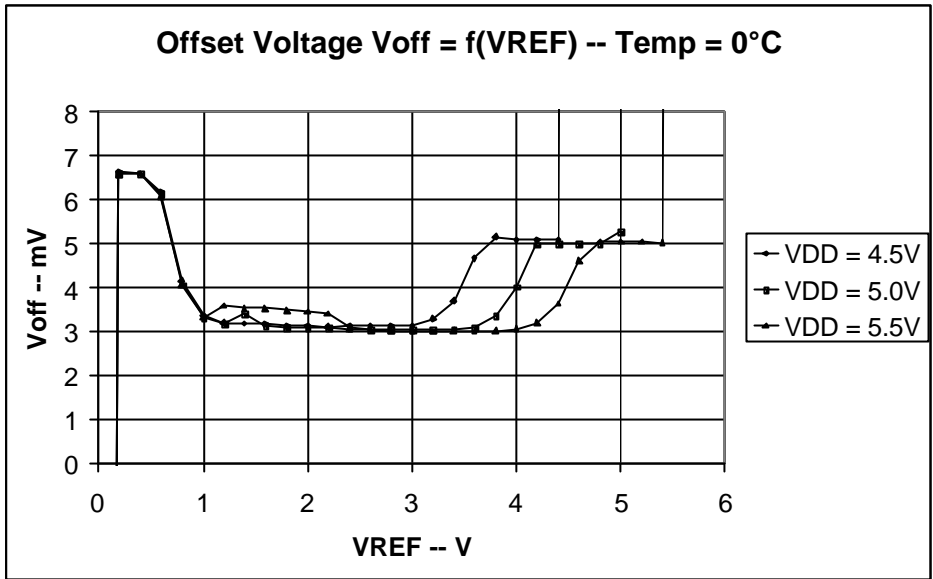

NO	VERSION	APPROVED
1	V 1.3	2001-01-10

5.3.2 Leakage Current At Input INX

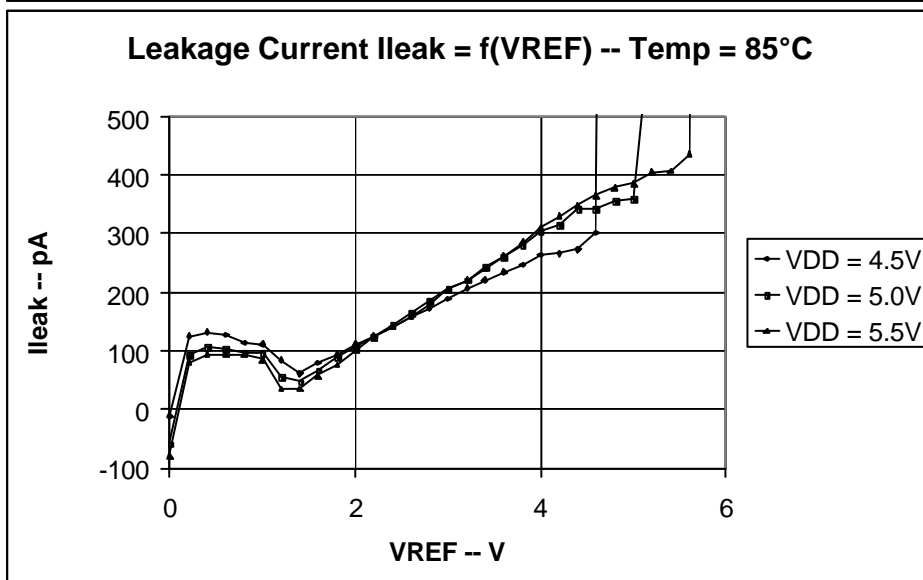
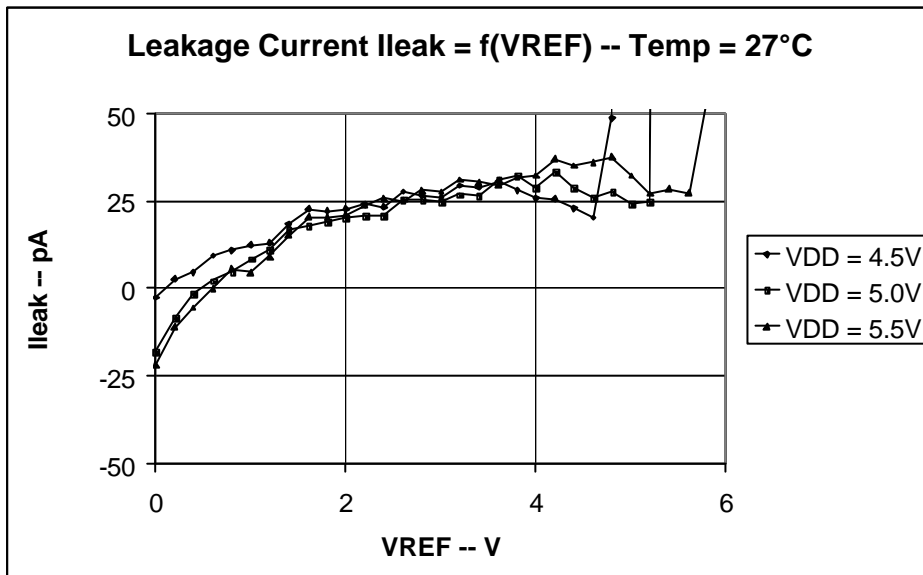
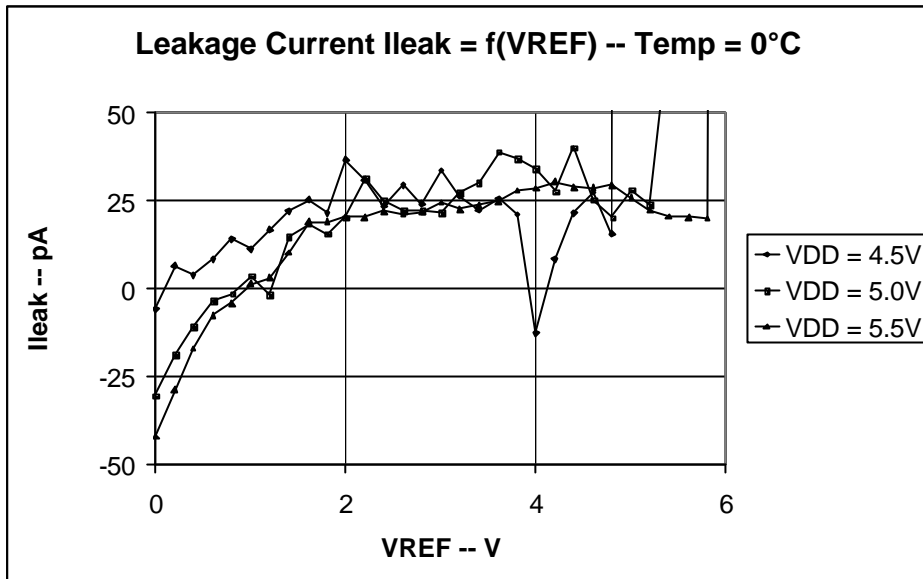

NO	VERSION	APPROVED
1	V 1.3	2001-01-10

5.3.3 DC-Transfer-Curves

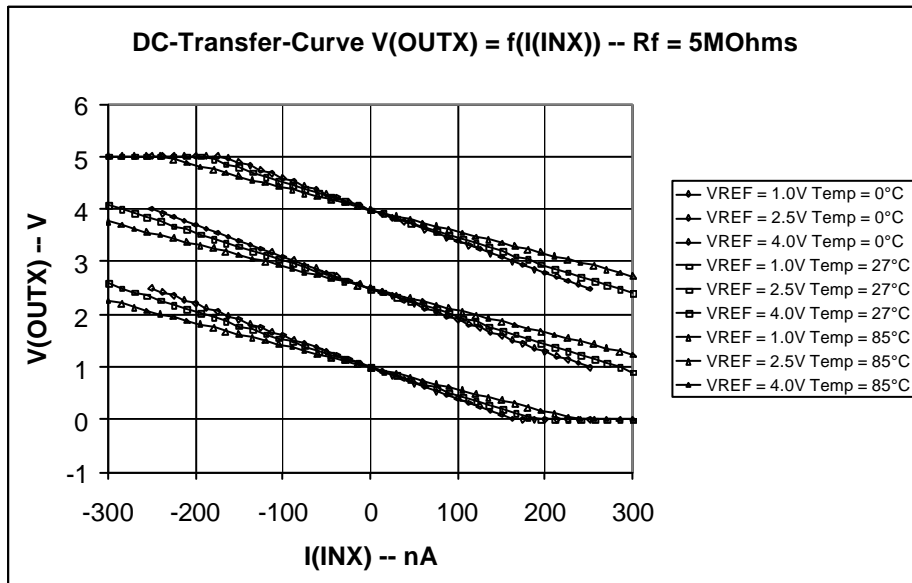
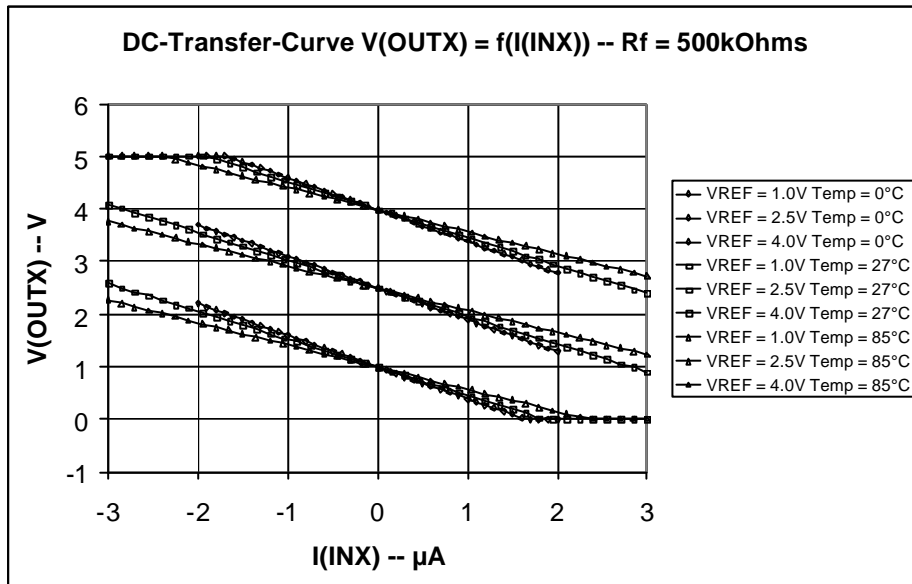
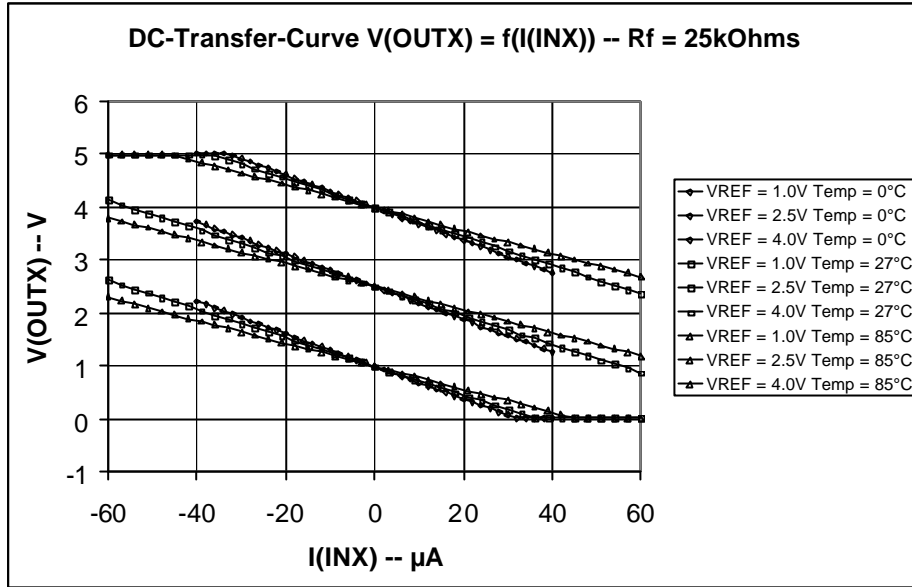

NO	VERSION	APPROVED
1	V 1.3	2001-01-10

## 6. PACKAGES

### 6.1 Shape and Dimensions

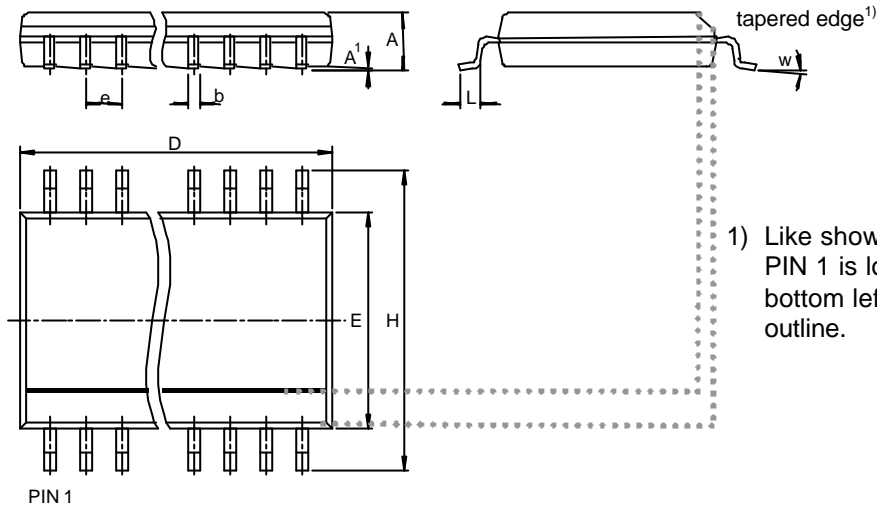

dimensions – mm

TYP	PACKAGE	D	E	H	A	A1	e	b	L	w
MTI04BS	SOP16	9,90	3,80	6,00	1,75	0,15	1,27	0,41	0,72	4°
MTI04BQ	QSOP16	4,90	3,80	6,00	1,75	0,15	0,635	0,38	0,72	4°
MTI08BS	SOP28L	17,90	7,49	10,31	2,54	0,20	1,27	0,41	0,76	4°
MTI08BQ	QSOP28L	9,9	3,8	6,0	1,75	0,15	0,635	0,38	0,72	4°

### 6.2 Pin-Configuration

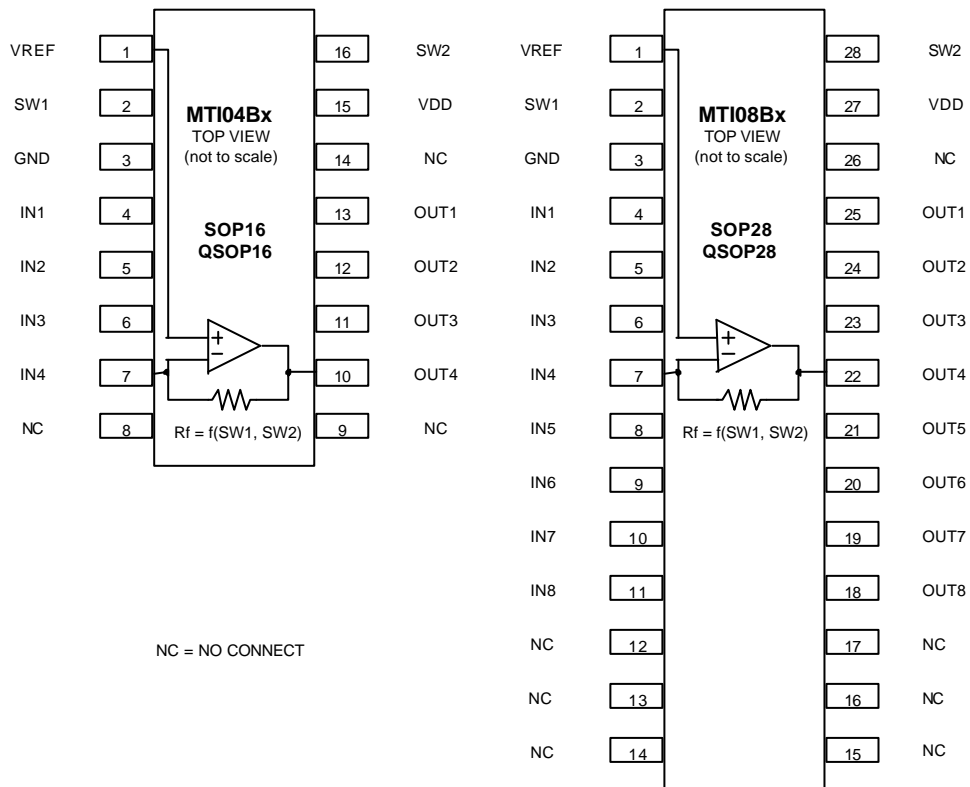

NO	VERSION	APPROVED
1	V 1.3	2001-01-10

## 7. APPLICATIONS

### 7.1 Example For Position Measurement

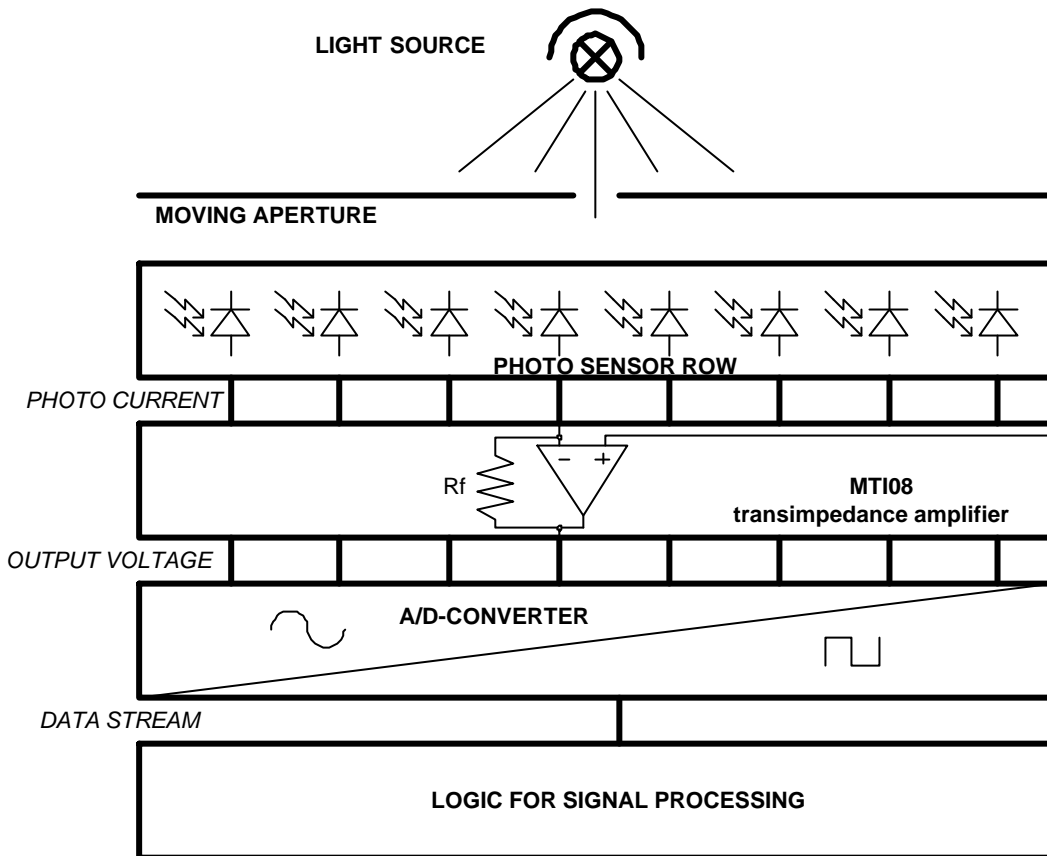

### 7.2 Connection Of A Colour Sensor

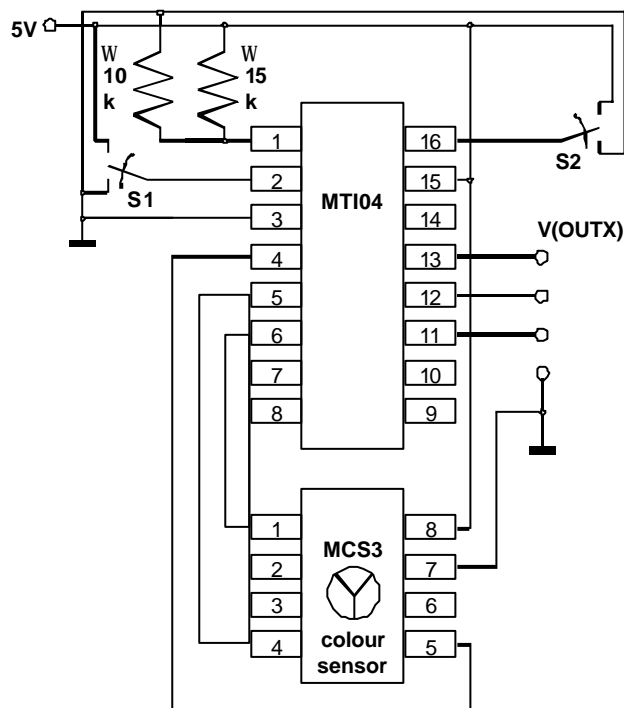

NO	VERSION	APPROVED
1	V 1.3	2001-01-10

## 8. ORDERING INFORMATION

NAME OF PRODUCT	PACKAGE	NUMBER OF CHANNELS
MTI04BS	SOP16	4
MTI04BQ	QSOP16	4
MTI08BS	SOP28	8
MTI08BQ	QSOP28	8

## 9. CONTACT

For further information, please feel free to contact:

---

**MAZeT GmbH**  
**Central Sales Office – Mr. Frank Krumbein**  
In den Weiden 7  
D-99099 Erfurt  
Phone: +49 361 44206-0  
Telefax: +49 361 44206-12  
Email: [sales@MAZeT.de](mailto:sales@MAZeT.de)  
<http://www.MAZeT.de>