

Power LED

White LED

SSW-13



1. FEATURES

- **Package:** white P-LCC-4 package
- **Size:** small package outline(L*W*H) of 3.2*2.8*1.9 mm
- **Feature of the device:** extremely wide viewing angle; ideal for backlighting and coupling in light guides
- **Chromaticity:** White(x, y)=0.30,0.31
- **Technology:** hyper bright InGaN/SiC dice
- **ESD:** up to 1kV acc. to EOS/ESD-5.1-1993
- **Viewing angle:** lambertian emitter(120°)
- **Grouping parameter:** luminous intensity, wavelength
- **Assembly methods:** suitable for all SMT assembly methods
- **Soldering methods:** IR reflow soldering and TTW soldering
- **Preconditioning:** acc. to JEDEC Level 2
- **Taping:** 8mm tape with 2000/reel, ϕ 180mm

2. APPLICATIONS

- traffic lights
- backlighting(LCD, cellular phone, switches, keys, displays, illuminated advertising, general lighting)
- interior and exterior automotive lighting(e.g. dashboard backlighting)
- marker lights(e.g. steps, exit ways, etc.)
- substitution of micro incandescent lamps
- reading lamps
- emergency lighting
- signal and symbol luminaries

3. SPECIFICATIONS

(1) Absolute Maximum Ratings (Ta=25°C)

Parameter	Symbol	Value	Unit
DC Forward Current	I_F	30	mA
Peak pulse current ($t_p \leq 10\mu$ s, Duty cycle=0.005)*1	I_{pulse}	1000	mA
Reverse Voltage	V_R	5	V
Power Dissipation	P_d	120	mW
LED junction Temperature	T_j	125	°C
Operating Temperature	T_{op}	-40 ~ +100	°C
Storage Temperature	T_{stg}	-40 ~ +100	°C

*1 Duty cycle:

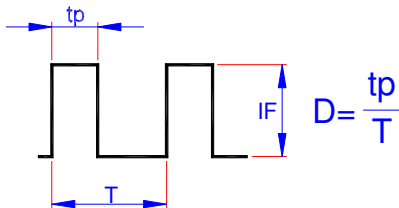

(2) Characteristics (Ta=25°C)

Color	Group	Chromaticity Coordinate Group				
DWW: White	Full	x	0.260	0.260	0.350	0.350
		y	0.310	0.250	0.370	0.310
	Wa-c	x	0.260	0.260	0.275	0.275
		y	0.310	0.250	0.320	0.260
	Wd-f	x	0.275	0.275	0.290	0.290
		y	0.320	0.260	0.330	0.270
	Xa-c	x	0.290	0.290	0.305	0.305
		y	0.330	0.270	0.340	0.280
	Xd-f	x	0.305	0.305	0.320	0.320
		y	0.340	0.280	0.350	0.290
	Ya-c	x	0.320	0.320	0.335	0.335
		y	0.350	0.290	0.360	0.300
	Yd-f	x	0.335	0.335	0.350	0.350
		y	0.360	0.300	0.370	0.310

Chromaticity Ranks

White Bin Structure

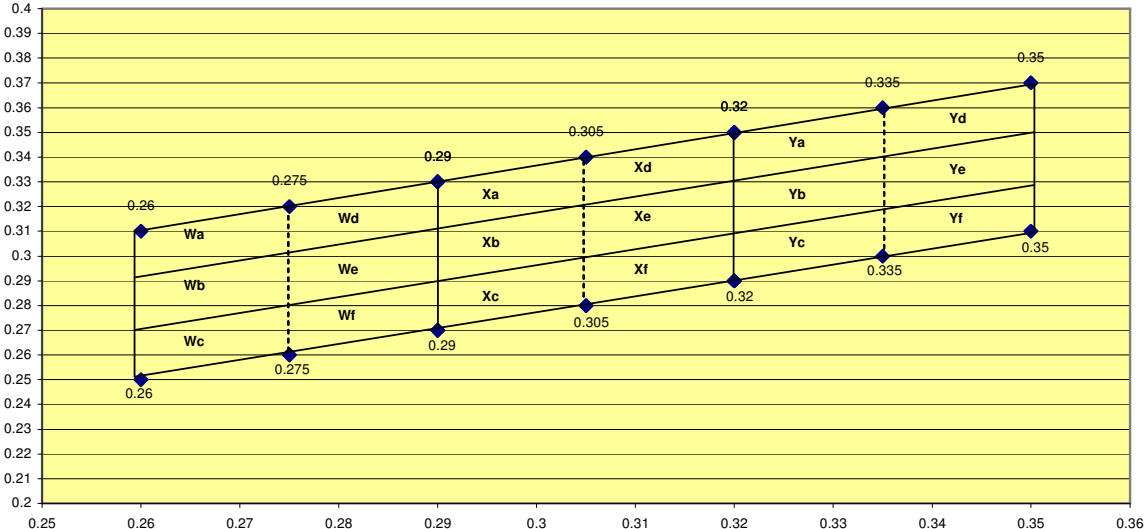

CIE Chromaticity Diagram

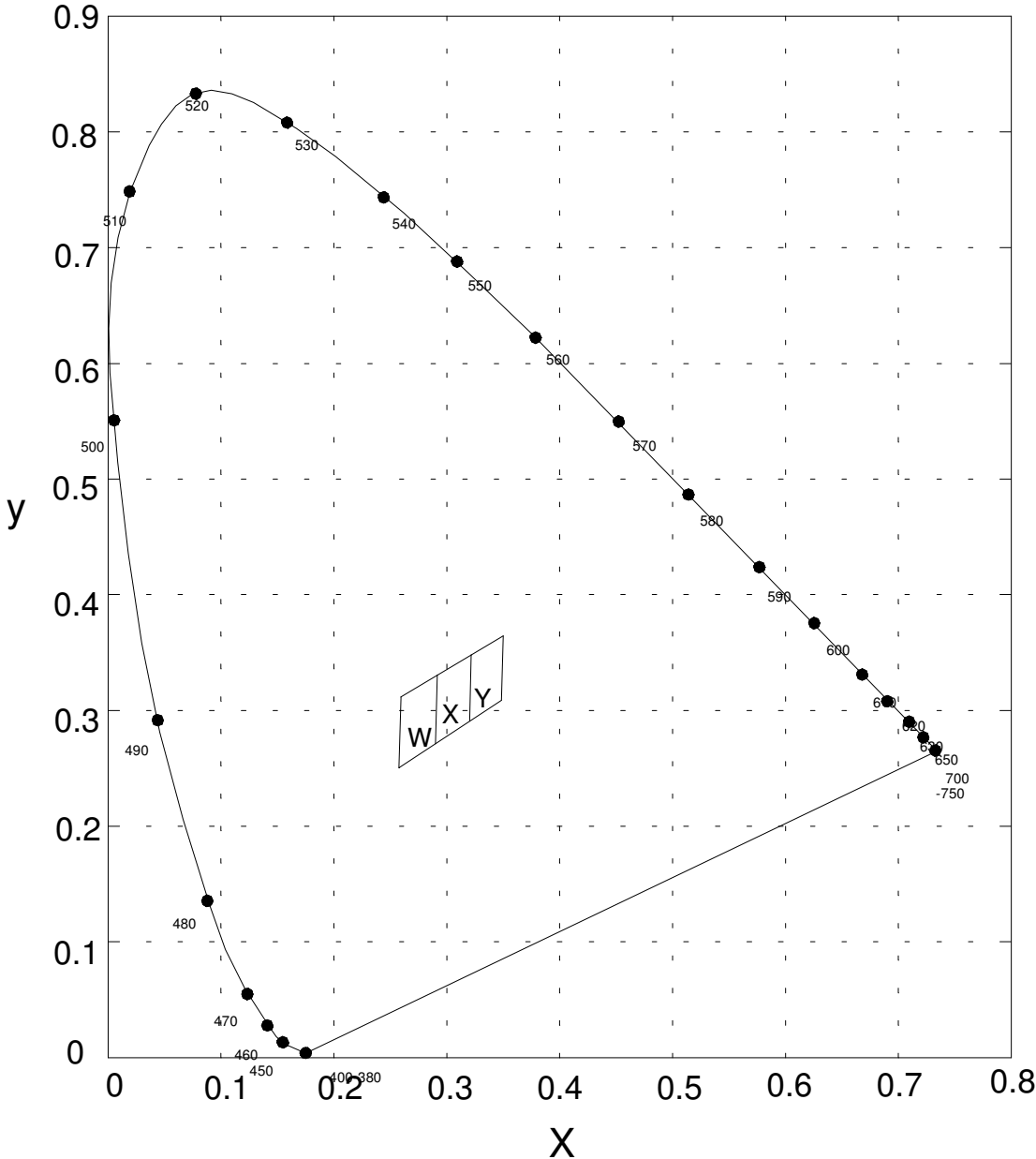

* The C.I.E. 1931 chromaticity diagram

Luminous Intensity Ranks

Intensity Group	Color of Emission	Luminous Intensity(mcd) @ $I_F=30mA$
SSW-13-UV2	White(x, y) = 0.30, 0.31	450.0 — 1125.0
• DWW-13-U1		450.0 — 560.0
• DWW-13-U2		560.0 — 715.0
• DWW-13-V1		715.0 — 900.0
• DWW-13-V2		900.0 — 1125.0

Forward Voltage Ranks

Voltage Group	Forward Voltage(V) @30mA
Standard	3.35 ~ 4.25
V01	3.35 ~ 3.65
V02	3.65 ~ 3.95
V03	3.95 ~ 4.25

Group Name on Label

Example: V1WEV02

Intensity Group	Chromaticity Group	Voltage Group
V1	We	V02

Note

- A. Luminous Intensity is measured with an accuracy of $\pm 11\%$.
- B. Color selection acc. to chromaticity coordinates groups and an accuracy of ± 0.01 .
- C. Forward Voltage is measured with an accuracy of $\pm 0.1V$.
- D. The standard shipping format for serial types all groups. Individual groups are not available.
- E. No packing unit 1 tape ever contains more than one group.

4. OUTLINE DIMENSIONS AND MATERIALS

Package Outline

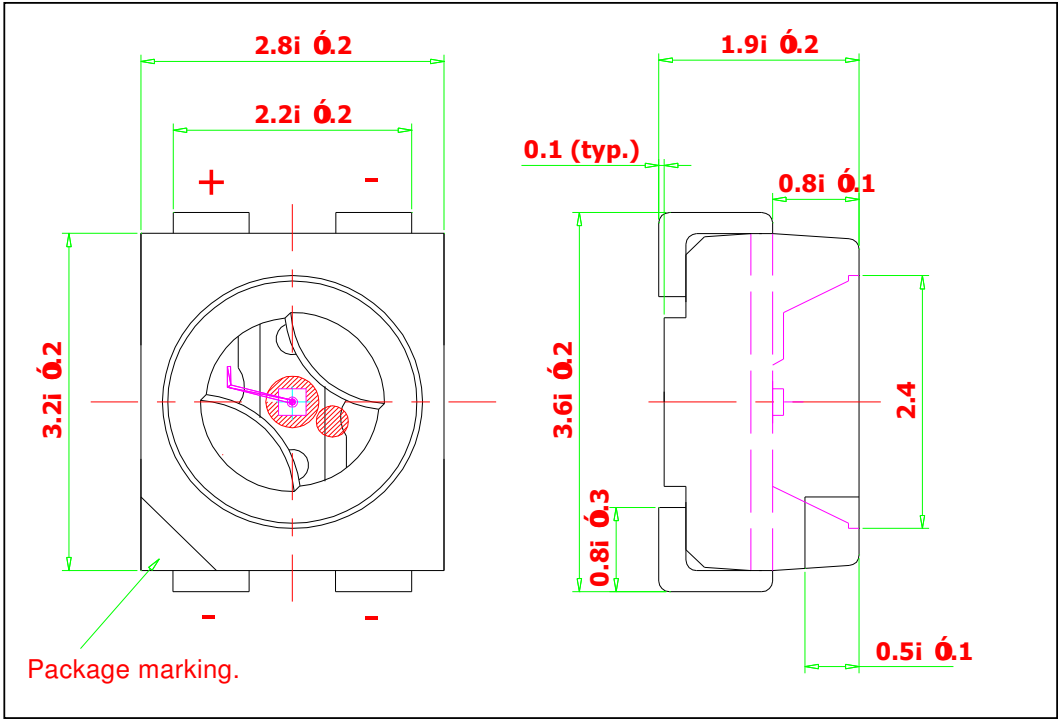

Dimensions are specified in mm unit and an accuracy of ±0.1mm

Material as follows

- Package : Heat-Resistant Polymer
- Encapsulating Resin : Epoxy Resin (With Diffused + YAG Phosphor)
- Electrodes : Ag Plating Copper Alloy

5. RELIABILITY

Product Reliability Qualification Plan

All units are to be pre-conditioned before proceeding to the respective test.

	Conditions
<ul style="list-style-type: none"> • Pre-conditioning as per JEDEC L • 2A requirement (JESD22-A113-B) • IR re-flow soldering on FR4 board. 	<ul style="list-style-type: none"> - Bake @ 125°C, 24 hrs. - Storage @ 60°C/60% RH, 120 hrs. - 3xIR re-flow soldering at 235°C/10 sec. min.(Jedec)

Failure criteria

- Electrical Failures:
 - V_F shift $\geq 10\%$
 - $V_R > 5V@10\mu A$
- Light Output Degradation:
 - % I_V shift $\leq -50\%$ max
 $\leq -35\%$ average
- Visual Failures:
 - Broken or damaged package or lead
 - Solder ability $< 95\%$ wetting
 - Dimension out of tolerance

Reliability Test Items and Results

IR/Convective Reflow Process at Peak Temperature 235°C±5°C for 10-20 sec

Pre-conditioning @ 60°C/60%RH for 120 hours

No	Test Item	Stress Condition	Sample Size	Test Point	Test Result
1	Ambient life test (ALT)	a) Pre-conditioning b) IR re-flow soldering - $T_a = 25^\circ\text{C}$, $I_F = 30\text{ mA}$	100	0 hrs 168 hrs 504 hrs 1000 hrs	100/100 pass
2	High temperature humidity elevated life test(ELT)	a) Pre-conditioning b) IR re-flow soldering - $T_a = 85^\circ\text{C}$, 85% RH, $I_F = 30\text{ mA}$	100	0 hrs 168 hrs 504 hrs 1000 hrs	100/100 pass
3	Pulse mode life test	a) Pre-conditioning b) IR re-flow soldering - $T_a = 25^\circ\text{C}$ $I_F = 100\text{ mA}$, $t_p=1\text{ms}$, $D=0.1$	100	0 hrs 168 hrs 504 hrs 1000 hrs	100/100 pass
4	Thermal shock (TSK)	a) Pre-conditioning b) IR re-flow soldering c) Liquid-to-liquid, -55°C to 100°C, 15 min dwell, < 10 sec transfer	100	0x, 50x, 100x, 500x	100/100 pass
5	High temperature storage(HTS)	100°C	100	0 hrs 168 hrs 504 hrs 1000 hrs	100/100 pass
6	Low temperature storage(LTS)	-40°C	100	0 hrs 168 hrs 504 hrs 1000 hrs	100/100 pass

6. CAUTIONS

Storage

- (1) Calculated shelf life in sealed bag: 12 months at <math><40^{\circ}\text{C}</math> and <math><90\%</math> relative humidity (RH)
- (2) Peak package body temperature: 240°C
- (3) After bag is opened, devices that will be subjected to reflow solder or other high temperature process must.
 - A. Mounted within: 672 hours of factory conditions $\leq 30^{\circ}\text{C}/60\%$
 - B. Stored at <math><10\%</math> RH
- (4) Devices require bake, before mounting, if:
 - A. Humidity Indicator Card is > 10% when read at - B. 3A or 3B not met.
- (5) If baking is required, devices may be baked for 20 hours at

Note

If device containers cannot be subjected to high temperature or shorter bake times are desired, reference IPC/JEDEC J-STD-033 for bake procedure.

Level and body temperature defined by IPC/JEDEC J-STD-020

Soldering

IR Reflow Soldering profile (acc. to IPC 9501)

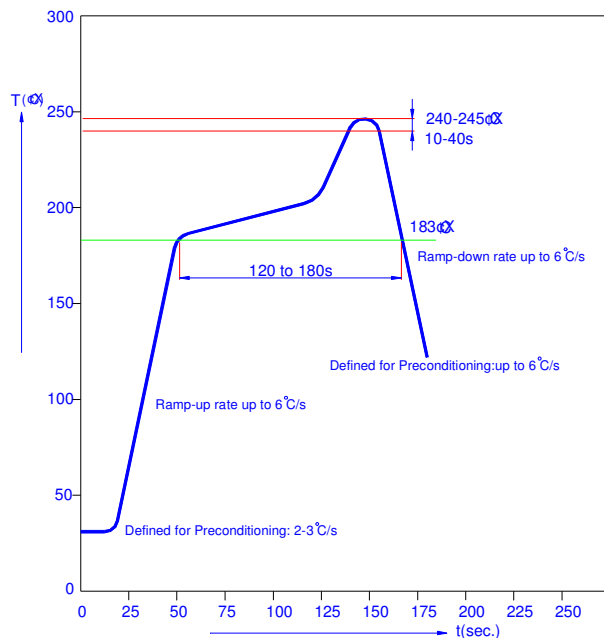

TTW Soldering (acc. to CECC 00802)

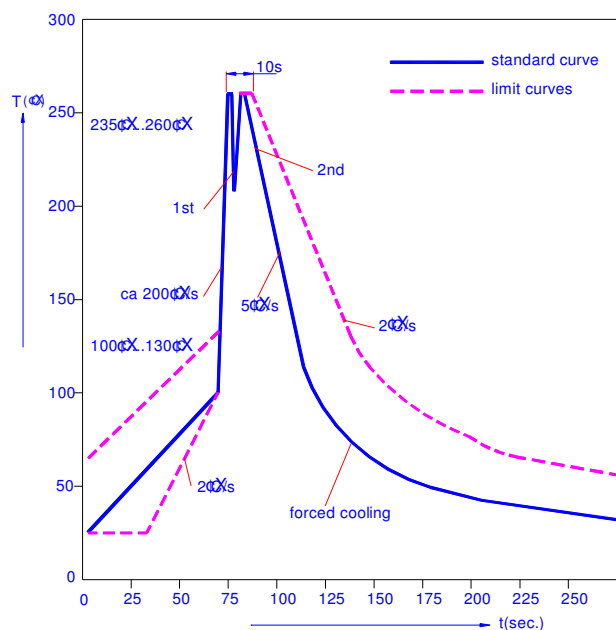

Recommended Solder Pad

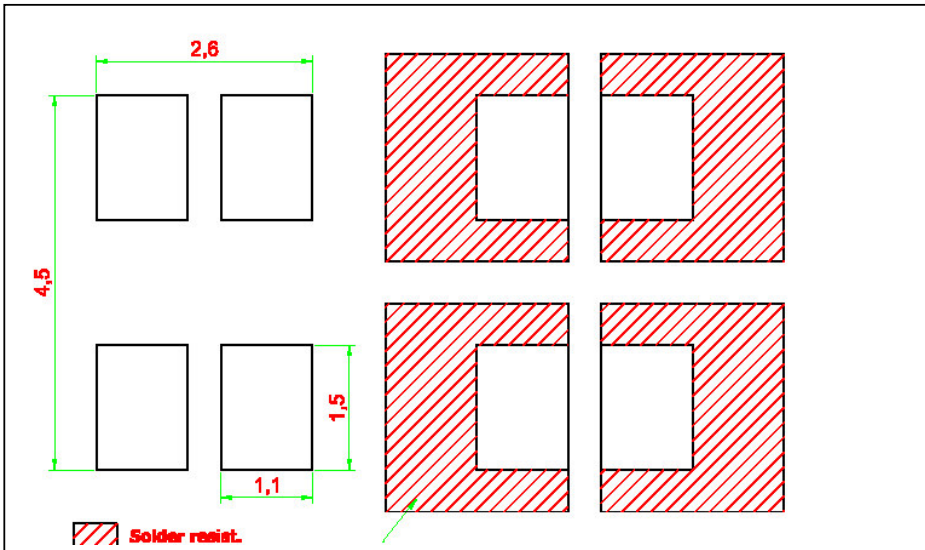

7. REVISION HISTORY

Version	Page	Subjects (major modified since last revision)	Date
1.0		New from	2002-12-20

8. NOTE

All the information published is considered to be reliable. However, the supplier does not assume any liability arising out of the application or use of any product described herein.

The supplier reserves the right to make changes at any time without notice to any products in order to improve reliability, function or design.

The supplier products are not authorized for use as critical components in life support devices or systems without the express written approval from the managing director of the supplier