

Spec No.	SS0309-046
Rev.	A0

PRODUCT SPECIFICATION

Model No:

Descriptions:

- 7.6*7.6 **Piranha** Type
- Emitting Color: **White**
- Viewing Angle: 60°
- Stopper

Spec No.	SS0309-046
Rev.	A0

■ Package Dimensions

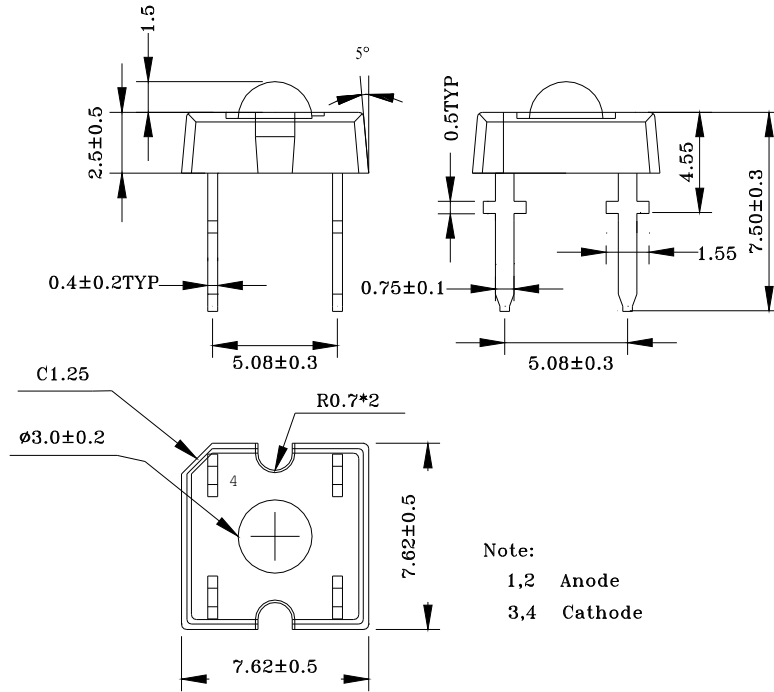

Note:
1,2 Anode
3,4 Cathode

Notes:

1. All dimensions in mm tolerance is ± 0.2 mm unless otherwise noted.
2. An epoxy meniscus may extend about 1.5mm down the leads.
3. Burr around bottom of epoxy may be 0.5mm max.

■ Far Field Pattern

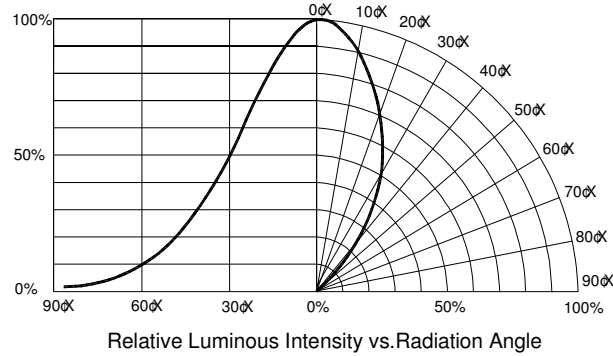

Spec No.	SS0309-046
Rev.	A0

■ Absolute Maximum Ratings (Ta = 25°C)

Items	Symbol	Absolute maximum Rating	Unit
Power Dissipation	P _D	150	mW
Forward Current(DC)	I _F	30	mA
Peak Forward Current*	I _{FP}	100	mA
Reverse Voltage	V _R	5	V
Electrostatic Discharge(Class2)	ESD	1000	V
Operation Temperature	T _{opr}	-20 ~ +75	°C
Storage Temperature	T _{stg}	-30 ~ +80	°C
Lead Soldering Temperature	T _{sol}	Max.260°C for 3 sec Max. (3mm from the base of the epoxy bulb)	

*Pulse width ≤ 0.1msec duty ≤ 1/10

■ Typical Electrical & Optical Characteristics (Ta = 25°C)

Items	Symbol	Condition	Min.	Typ.	Max.	Unit
Forward Voltage	V _F	I _F = 30mA	3.4	4.0	4.6	V
Forward Voltage	V _F	I _F = 20mA	3.2	3.6	4.2	V
Reverse Current	I _R	V _R = 5V	---	---	50	μA
Chromatic Coordinates	(x,y)	I _F = 20mA	---	(0.31,0.32)	---	---
Luminous Flux	Φ _v	I _F = 30mA	---	2800	---	mlm
Luminous Intensity	I _v	I _F = 20mA	---	1100	---	mcd
50% Power Angle	2θ _½	I _F = 20mA	---	60	---	Deg

■ Ranks Combination

Rank(IF = 20mA)	Q	R	S
Luminous Intensity (mcd)	580-810	810-1135	1135-1590

Rank(IF = 30mA)	D	E	F
Luminous Flux(mlm)	2000-2750	2750-3850	3850-5400

■ Notes:

1. Tolerance of measurement of luminous flux or Intensity : ±15%
2. Tolerance of measurement of chromatic coordinates : ±0.02
3. Tolerance of measurement of forward voltage : ±0.05V
4. All ranks will be included per normal delivery and rank ratios will be determined by supplier.
5. Please confirm with supplier, if your request different from standard specification.

■ Chromatic Coordinates Ranks

Rank	W1				W2				W3				W4				W5			
x	0.250	0.250	0.260	0.260	0.260	0.260	0.270	0.270	0.270	0.270	0.280	0.280	0.280	0.280	0.290	0.290	0.290	0.290	0.300	0.300
y	0.165	0.250	0.265	0.180	0.180	0.265	0.280	0.195	0.195	0.280	0.295	0.210	0.210	0.295	0.310	0.225	0.225	0.310	0.325	0.240

Rank	W6				W7				W8				W9				W10			
x	0.300	0.300	0.310	0.310	0.310	0.310	0.320	0.320	0.320	0.320	0.330	0.330	0.330	0.330	0.340	0.340	0.340	0.340	0.350	0.350
y	0.240	0.325	0.340	0.255	0.255	0.340	0.355	0.270	0.270	0.355	0.370	0.285	0.285	0.370	0.385	0.300	0.300	0.385	0.400	0.315

■ CIE Graph

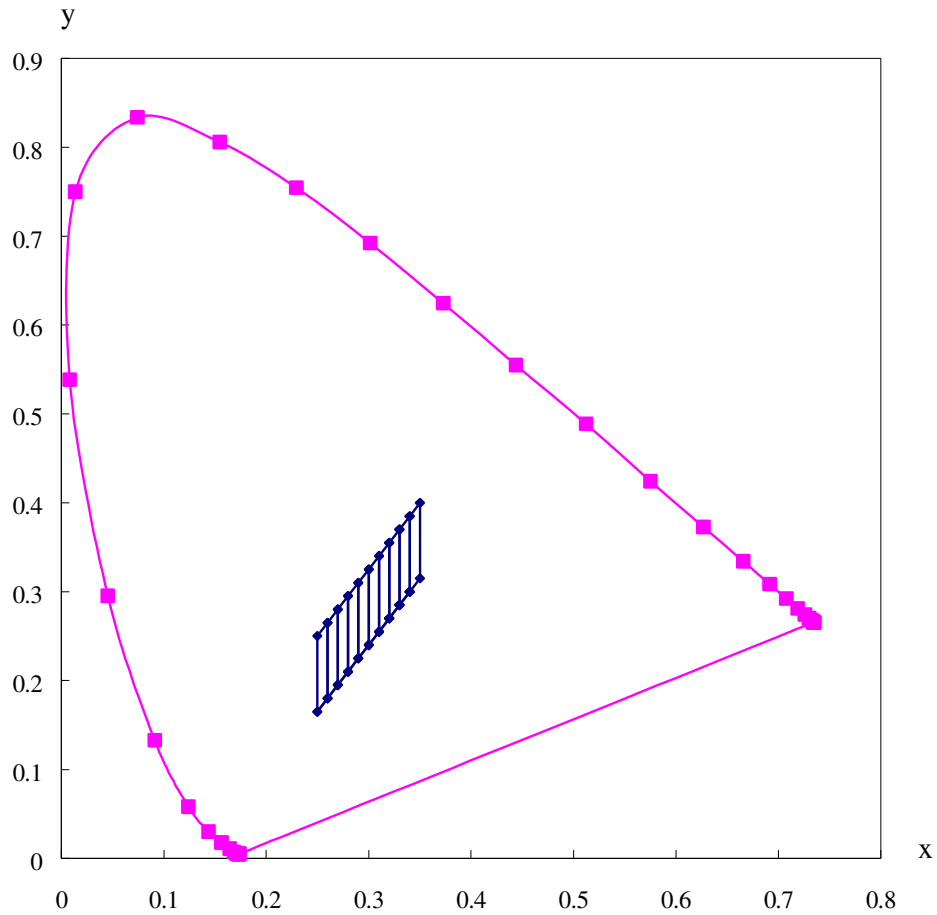

Spec No.	SS0309-046
Rev.	A0

■ Typical Electrical/ Optical Characteristics Curves
(Ta=25°C Unless Otherwise Noted)

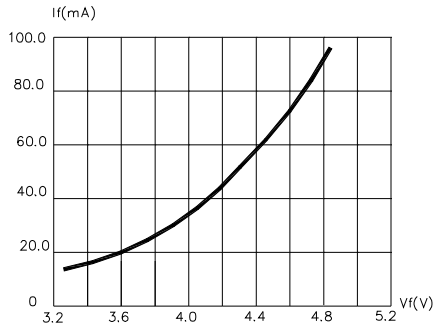

Fig.1 Forward Current vs. Forward Voltage

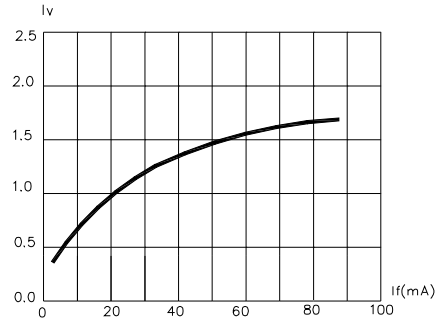

Fig.2 Relative Luminous Intensity vs. Forward Current

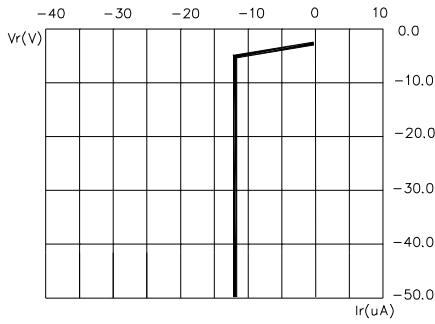

Fig.3 Reverse Current vs. Reverse Voltage

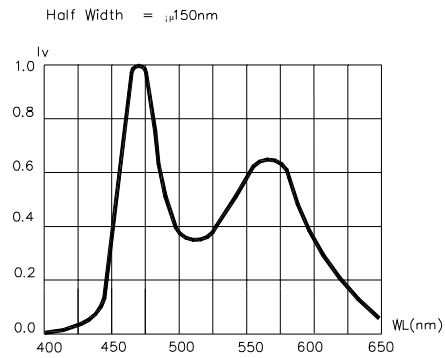

Fig.4 Relative Luminous Intensity vs. Wavelength

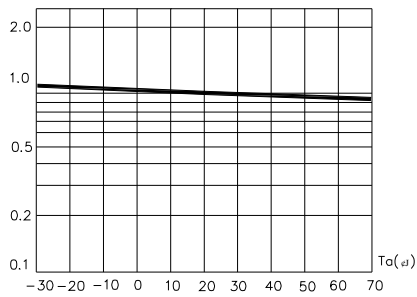

Fig.5 Relative Luminous Intensity vs. Ambient Temperature

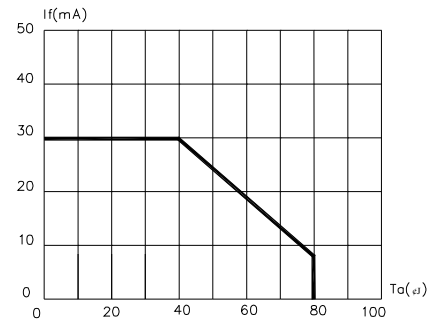

Fig.6 Maximum Forward Current vs. Ambient Temperature

Spec No.	SS0309-046
Rev.	A0

■ Reliability

1. Test Items And Results

Test Item	Standard	Test Conditions	Note	Number of Damaged
Resistance to soldering Heat	JEITA ED-4701 300 302	Ta=260±5□ 10sec	1 time	0/22
solderability	JEITA ED-4701 300 303	Ta=230±5□ 5sec	1 time over 95%	0/22
Terminal Strength		1 Pound. 10Sec	No noticeable damage	0/22
Lead Fatigue		3 ×30° bend.3 oz	No noticeable damage	0/22
Power & Temperature cycle		-40□-25□-85□-25□ 30min 30min 30min 30min IF=50mA 5minute on/off	50 cycles	0/22
Temperature cycle		-40□~120□ 15min 15min 5minute transfer	300 cycles	0/22
High Humidity Heat Life Test		Ta=85° RH=85% IF=30mA	1000hrs (168,500,1000)	0/22
High Humidity Reverse BIAS Test	IEC 749	Ta=85° RH=85% Vr=5V	1000hrs (168,500,1000)	0/22
High Temperature Life Test		Ta=100□ IF=15mA	1000hrs (168,500,1000)	0/22
Life Test		Ta=25□ IF=50mA	1000hrs (168,500,1000)	0/22
Low Temperature Life Test		Ta=-40□ IF=50mA	1000hrs (168,500,1000)	0/22

2. Criteria for Judging The Damage

Item	Symbol	Test Conditions	Criteria for Judgment	
			Min.	Max.
Forward Voltage	V _F	I _F =50 mA	---	Initial Data ×1.1
Luminous Intensity	I _V	I _F =50 mA	Initial Data × 0.5	---
Reverse Current	I _R	V _R = 5V	---	Initial Data ×2.0